



US011330207B1

(12) **United States Patent**  
**Dierickx**

(10) **Patent No.:** **US 11,330,207 B1**

(45) **Date of Patent:** **May 10, 2022**

(54) **HIGH DYNAMIC RANGE IN DIRECT INJECTION**

(71) Applicant: **Caeleste CVBA**, Mechelen (BE)

(72) Inventor: **Bart Dierickx**, Edegem (BE)

(73) Assignee: **CAELESTE CVBA**, Mechelen (BE)

(\* ) Notice: Subject to any disclaimer, the term of this patent is extended or adjusted under 35 U.S.C. 154(b) by 0 days.

(21) Appl. No.: **17/186,277**

(22) Filed: **Feb. 26, 2021**

(51) **Int. Cl.**  
**H04N 5/355** (2011.01)  
**H04N 5/359** (2011.01)  
**H04N 5/378** (2011.01)

(52) **U.S. Cl.**  
CPC ..... **H04N 5/3559** (2013.01); **H04N 5/3594** (2013.01); **H04N 5/378** (2013.01)

(58) **Field of Classification Search**  
CPC ..... H04N 5/355; H04N 5/3594; H04N 5/378  
See application file for complete search history.

(56) **References Cited**

U.S. PATENT DOCUMENTS

2004/0041077 A1\* 3/2004 Fossum ..... H01L 27/14609  
250/208.1  
2011/0211103 A1\* 9/2011 Sakano ..... H04N 5/37452  
348/308  
2014/0263947 A1 9/2014 Dierickx

\* cited by examiner

*Primary Examiner* — Nicholas G Giles

(74) *Attorney, Agent, or Firm* — Workman Nydegger

(57) **ABSTRACT**

A pixel structure and a method of reading charges generated by a radiation sensing element upon exposure thereof to radiation is presented. The pixel structure comprises at least two capacitors configured for integrating charge from a radiation sensing element, where an overflow transistor sets a predetermined threshold level by a static voltage on its control electrode. This allows charges generated in the radiation sensing element to be integrated in either the first capacitor for a level of charge generated by the radiation sensing element, while the level remains under a predetermined threshold level, or in the at least one further capacitor for a level of charge generated by the radiation sensing element when said level surpasses said predetermined threshold level. At least one merge switch is used for merging the charges of the first capacitor with the charges of the at least one further capacitor.

**14 Claims, 8 Drawing Sheets**

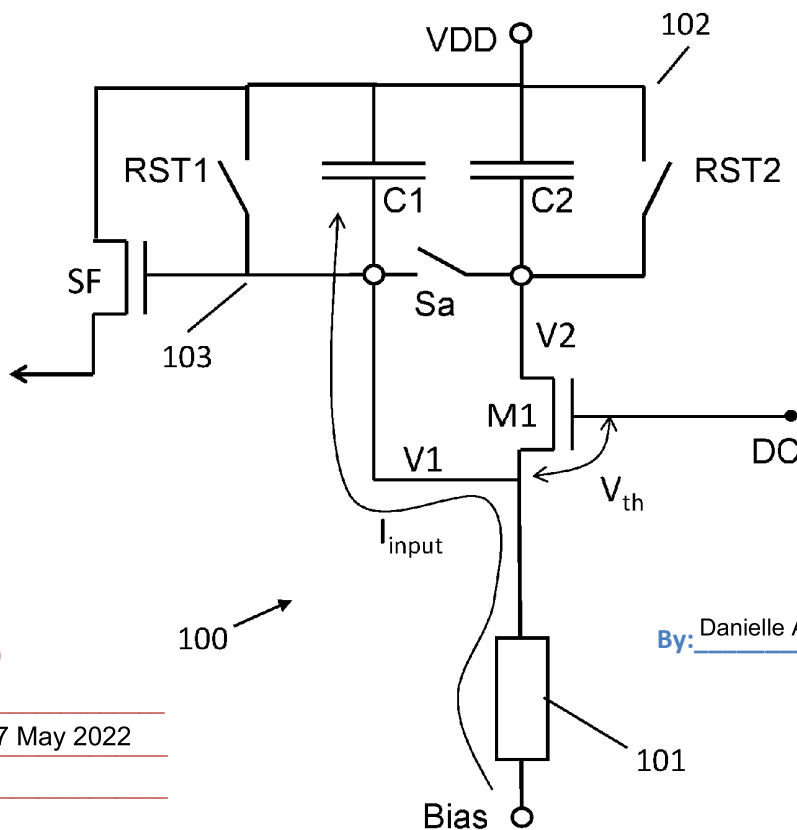

Verified

By: Danielle Anderson On: 17 May 2022

**DOCKETED**

Atty JJC File# 19828.454

By Steffanie Smith On 17 May 2022

Action Expiration

Response Due 26-Feb-2041

Renewals Handled Elsewhere