

## Two-color indirect X-ray photon counting image sensor

Bart Dierickx, Stijn Vandewiele, Benoit Dupont, Arnaud Defernez, Nick Witvrouwen, Dirk Uwaerts

Caeleste, Generaal Capiaumontstraat 11, 2600 Antwerp, Belgium

Email [bart@caeleste.be](mailto:bart@caeleste.be) tel. +32 478 299757

### Introduction

In X-ray imaging, as in other imaging domains, the ultimate sensitivity and signal to noise ratio is reached in the so-called “quantum limit”, counting each photon separately. Present state of the art digital radiography is largely “charge integration” based, which results in a read noise that is composed of the quantum limited photon shot noise, but also of electronic read noise and excess noise due to the non-reproducible charge packet sizes per absorbed X-ray photon.

A second advantage of photon counting is the capability of photon energy discrimination. The imager presented here creates a two-color X-ray image by counting X-ray photons using two different energy thresholds, in each pixel.

From electronics standpoint state-of-the-art photon counting pixels [1,2,3,4] should use direct detection, whereby the X-ray to charge conversion happens by the photo-electric effect in a high-Z semiconductor photoconductor or photodiode, depositing a charge packet of 5000 to 25000 electrons to the charge sensitive amplifier. However, as high-Z semiconductors are not economically manufacturable for large areas we stick to *indirect* detection, using scintillators. Indirect detection is inefficient, resulting in a charge packet per X-photon of only 100 to at most 500 electrons depending on scintillator characteristics and X-photon energy.

We solve the challenges by integrating two energy channels into each pixel, while keeping the effective transistors count at 45, maintaining a fill factor of ~80%, in an array size of 90x92 pixels (Fig 5). This can be considered as a FoM of 22.5 transistors per channel per pixel which is far below any previous design [2, 3]. This is reached by the concept of analog counting [1] and by the circuit compactness of the comparator and band pass filter (fig 2). For large arrays the specifications under challenge are yield, the pixel to pixel uniformity and the inter-pixel electrical crosstalk.

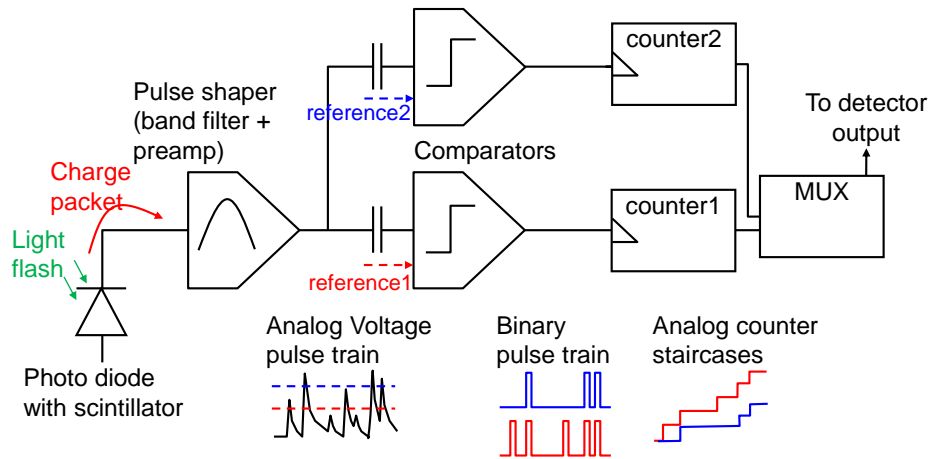

**Fig. 1. Overall pixel schematic of the two energy channel pixel, in total 45 transistors**

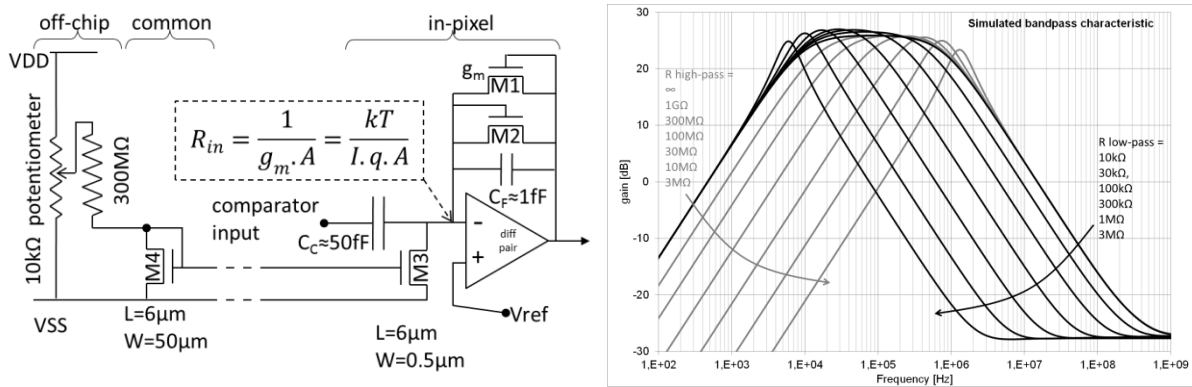

**Fig. 2. One comparator as of fig. 1 (left). The input C serves also as high-pass filter. Combined bandpass characteristics can be widely tuned (right).  $R_{\text{high-pass}} \sim 1\text{G}\Omega$  and  $R_{\text{low-pass}} \sim 100\text{k}\Omega$ .**

### Image acquisition and measurement results

Measurements were done at room temperature, with X-ray illumination in the 40 to 80kVp range. We used GdOS or CsI scintillators. For the yield, one of the key scaling related specs, we found out of 20 CoB assembled devices only 1 failing pixel in 1 device. . The electrical crosstalk between pixels proves not significant.

Series of image frames under continuous X-ray illumination were recorded. Fig. 4 shows the analog outputs of one unobstructed pixel over time, and the histogram thereof. In Fig. 5 a full 92x90 pixel image (of a DIL socket) using the CsI scintillator is shown. The frame to frame noise is slightly higher than the expected photon shot noise, likely due to X-ray source noise or device noise. We see an anomaly in the low threshold image where the flux through the plastic part of the socket seems the same as the background, yet features higher temporal and spatial randomness. DQE and MTF measurements in calibrated conditions are underway.

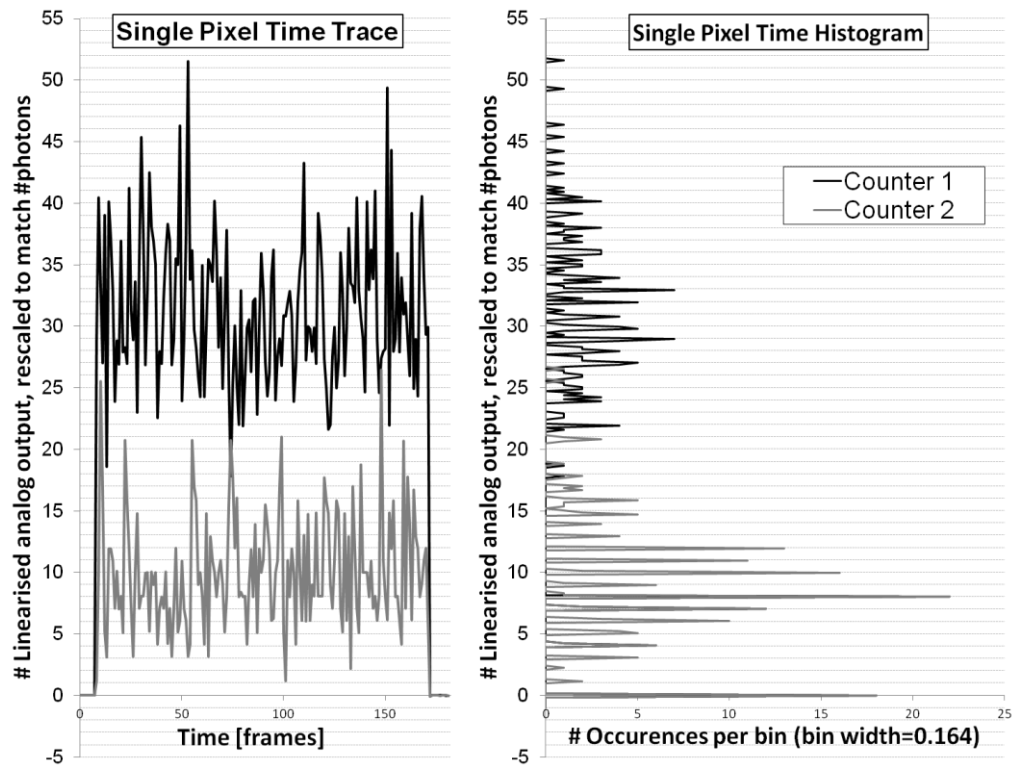

Fig. 4. time trace (left) and corresponding histogram (right) of the analog values of the two channels of one pixel. The Y-axis is the linearized output of the pixel, scaled to match an integer photon count.

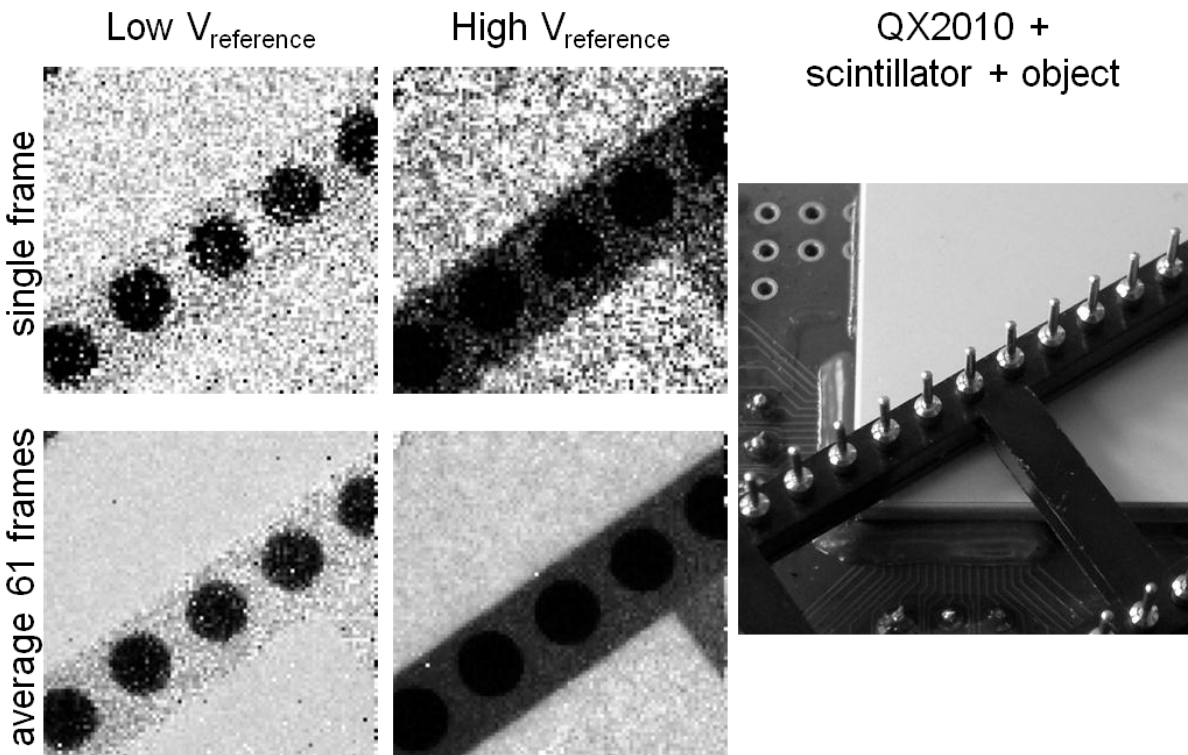
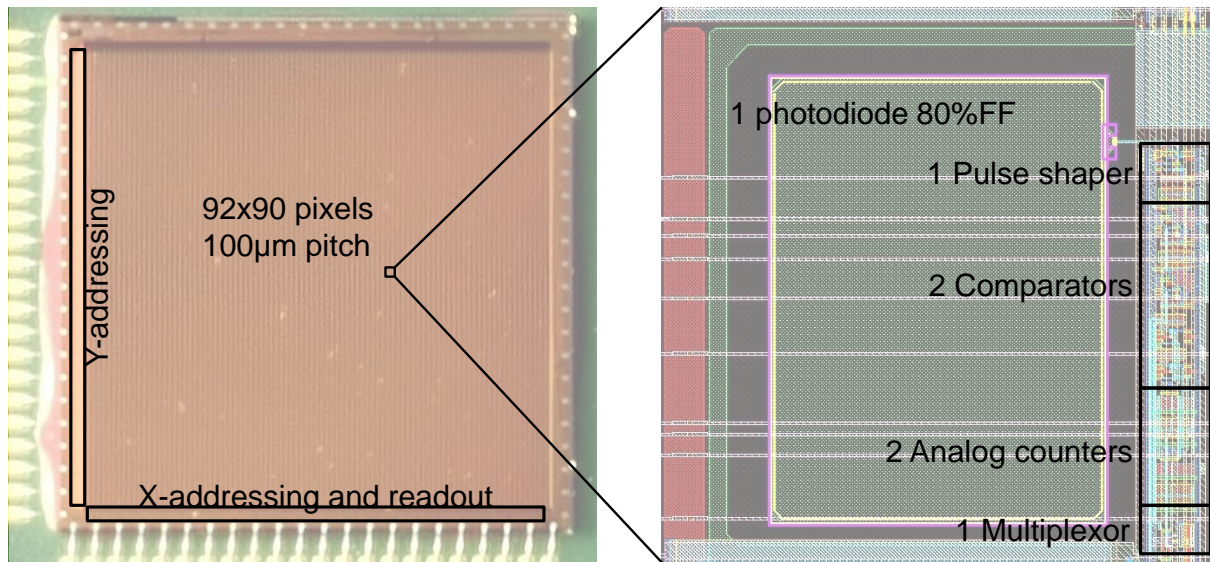

Fig. 5. X-ray image in two channels (left, right) of a DIL socket. Single frame (upper) and averaged over 61 frames (lower). Illumination 40kVp, 25mA, shielding 10mm Al.  $t_{\text{frame}}=180\text{ms}$ , dose= $232\mu\text{Gy}$ .



**Fig. 6. Microphotograph of the QX2010 IC, 1cm<sup>2</sup> in 0.18µm CMOS (left) and a layout plot of one 100µm pixel (right).**

## References

- [1] B. Dierickx et. al, "Indirect X-ray Photon-Counting Image Sensor with 27T Pixel and 15e<sup>-</sup><sub>rms</sub> Accurate Threshold," , ISSCC Dig. Tech Papers, 6.6, 2011.
- [2] R. Ballabriga et. al., "The Medipix3 Prototype, a Pixel Readout Chip Working in Single Photon Counting Mode With Improved Spectrometric Performance", IEEE Trans Nuclear Science, vol.54, no.5, 2007 , and references therein
- [3] W. Barber et. al., "Large Area Photon Counting X-Ray Imaging Arrays for Clinical Dual-Energy Applications", NSS-MIC, Oct 30, 2009
- [4] J. Iwaczyk et. al., "Photon Counting Energy Dispersive Detector Arrays for X-ray Imaging", IEEE Trans Nuclear Science, vol.56, no.3, p.535, June 2009
- [5] B. Dierickx, B.Dupont, A.Defernez, N.Ahmed, "Color X-ray photon counting image sensing", IISW, Hakodate Japan, June 2011